

## NRG Yukon Log Roll NG220S & NG220B

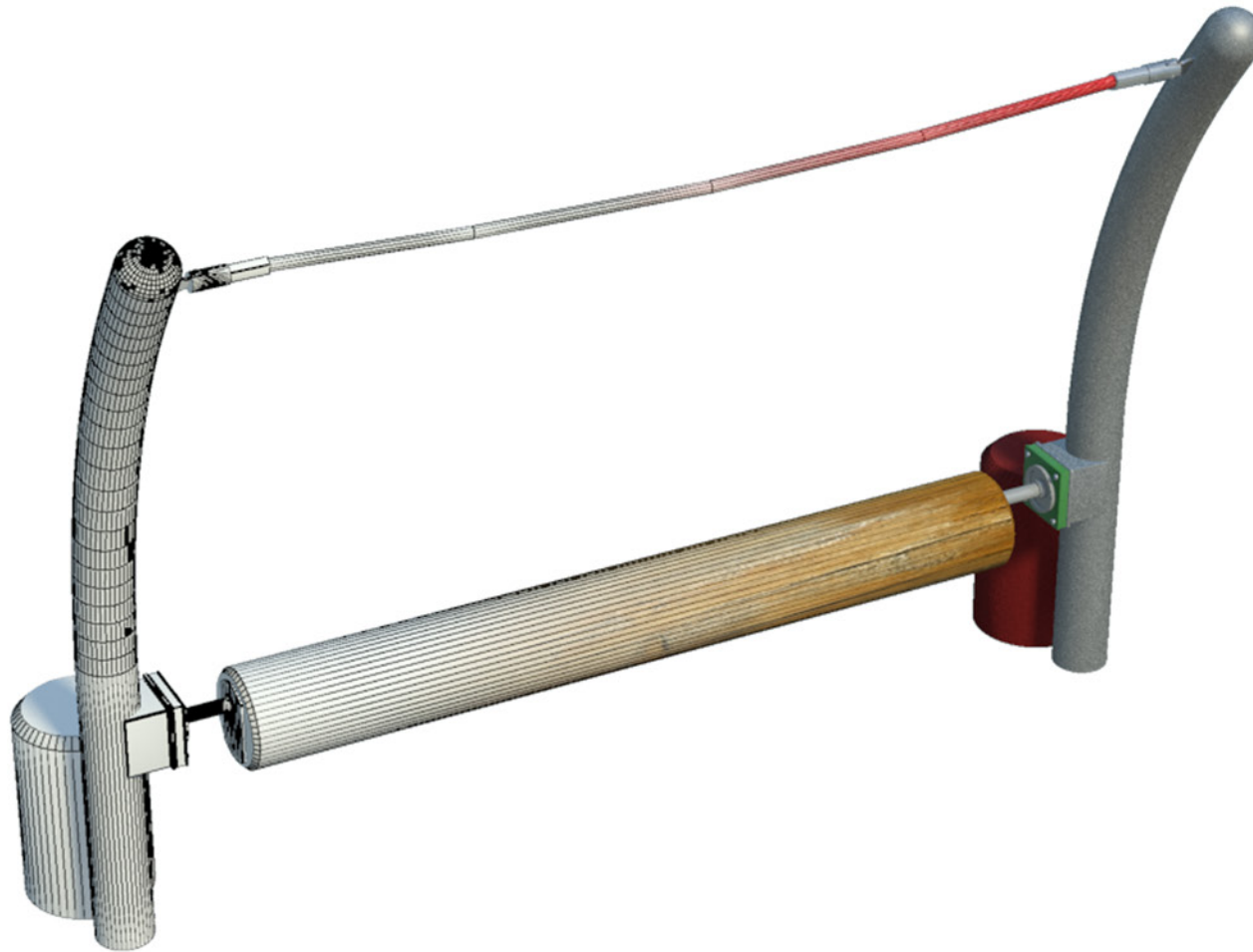
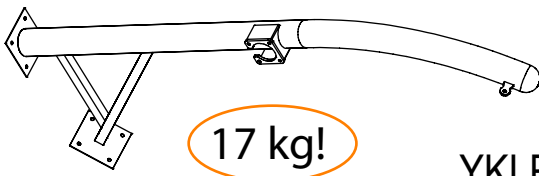
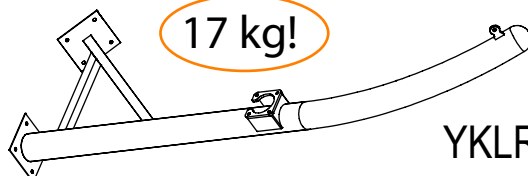
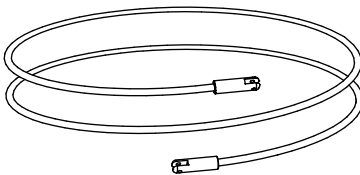

**1**  **78803024**  
**1 No**  
 17 kg!  
 YKLR Left Hand Post

**2**  **78803023**  
**1 No**  
 17 kg!  
 YKLR Right Hand Post

**3**  **78805036**  
**1 No**  
 1930mm Long Hand Rope

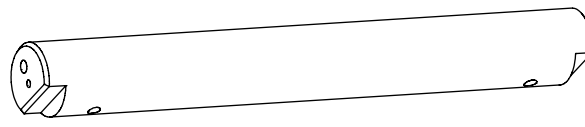
**4**  **78804004**  
**1 No**  
 Timber Log

**5**  **78804007**  
**2 No**  
 Log Mounting Shaft

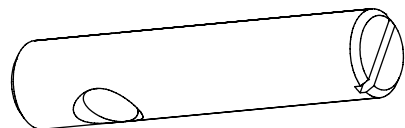
**6**  **780-578**  
**2 No**  
 120mm Barrel Nut

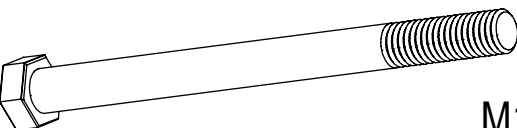
**7**  **780-574**  
**2 No**  
 M16 x 190mm Bolt

**8**  **10301600**  
**2 No**  
 M16 Shakeproof Washer

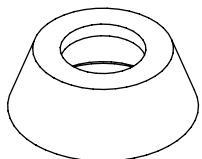
**9**  **10301601**  
**2 No**  
 M16 Armour Ring

**10**  **78804016**  
**2 No**  
 Bearing Assembly

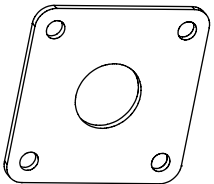
**11**  **78804009**  
**2 No**  
 Bearing Plate

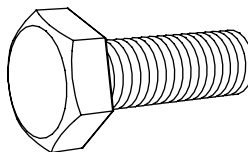
**12**  **10231240**  
**8 No**  
 M12 x 40 Bolt

13

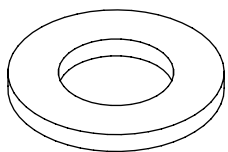

**10381200**  
**8 No**  
M12 Plain Washer

15

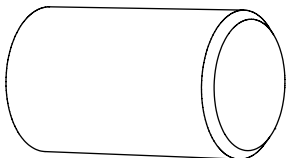

**RYBL400**  
**2 No**  
400mm Red Bollard

17



**RYADHBK**  
**1 No**  
Bollard Adhesive

<http://www.alansonsuk.com/downloads.asp>

14

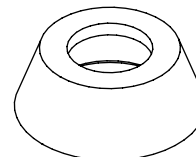

**10301201**  
**8 No**  
M12 Armour Ring

16

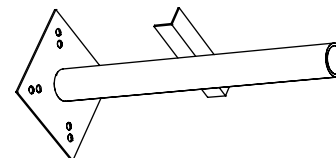

**803704**  
**2 No**  
400mm Bollard Fix Post

18

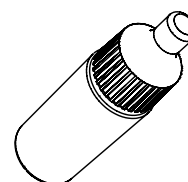

**950040**  
**1 No**  
High Strength Thread Lock



19

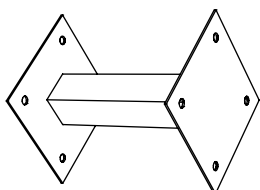

**305802**  
**6 No**  
Extension Unit

21

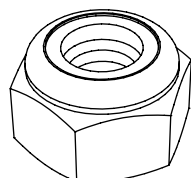

**10321000**  
**24 No**  
M10 Nyloc Nut

20

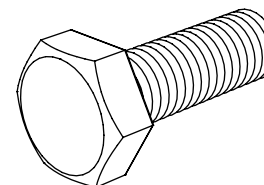



**10231040**  
**24 No**  
M10 x 40 Bolt



**NG220B**



**GB** - Verify ropes fit – remove before concreting  
**ES** – Utilizar las cuerdas para verificar la distancia entre los postes - quitarlas antes de poner el hormigón  
**FR** – Utiliser les cordes pour vérifier la distance entre les poteaux - les retirer avant bétonnage  
**DE** – Überprüfen Sie, dass die Seile passen - vor der Betonierung  
**IT** – Usare le corde come distanziali – rimuoverle prima di cementare i pali  
**SE** – Kontrollera att de linorna passa - flyttas innan betongarbete

**! - NG220B**

	144
	TYPE 1
	144
	TYPE 2



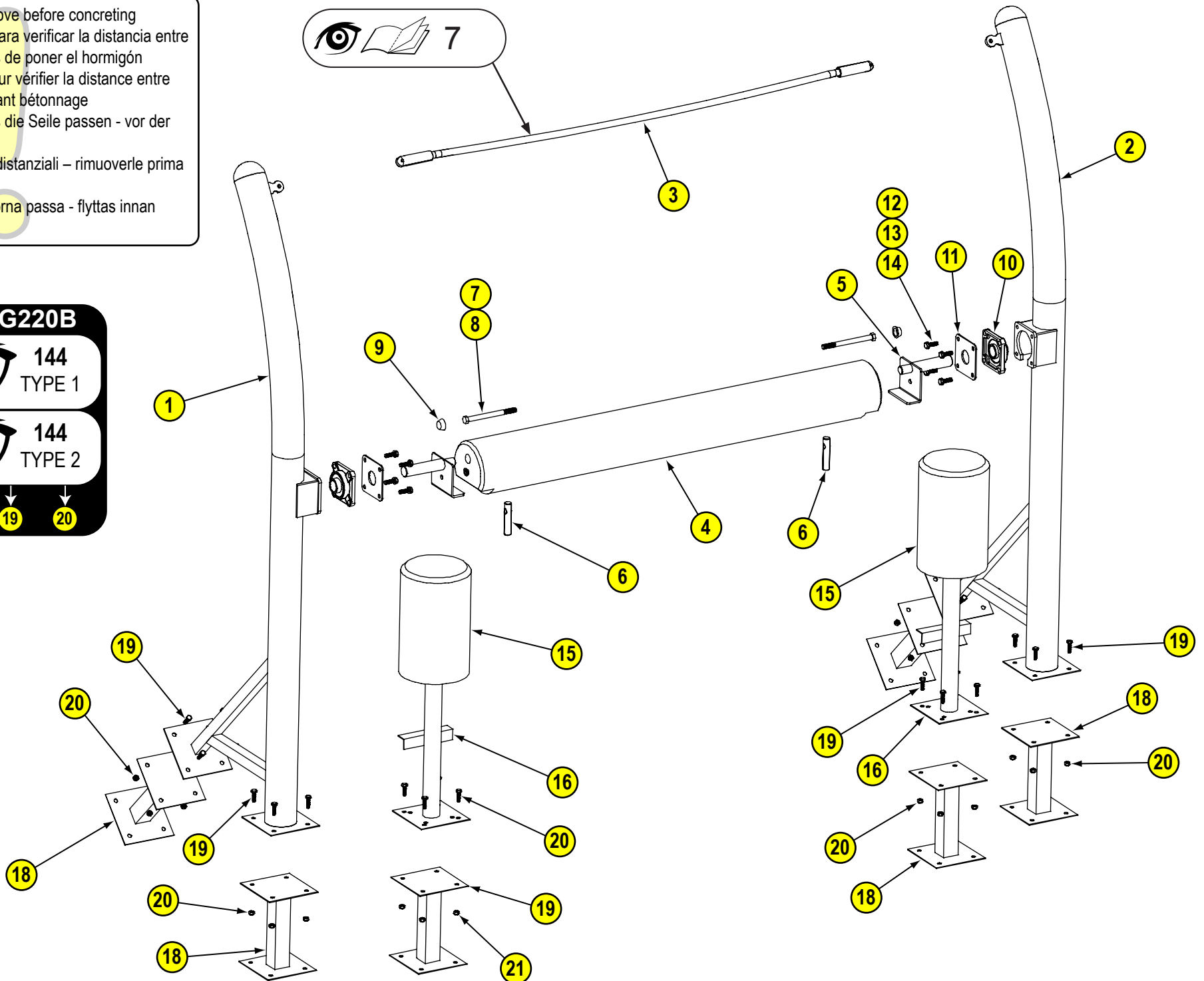



**NG220B**

 **144**  
TYPE 1

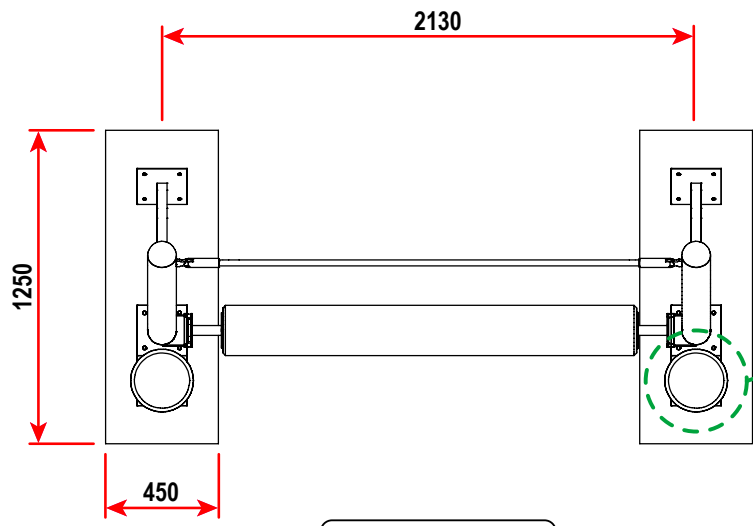
 **144**  
TYPE 2

m<sup>3</sup>  
1.00

LxWxH (m)  
1.25 x 0.45 x 0.85

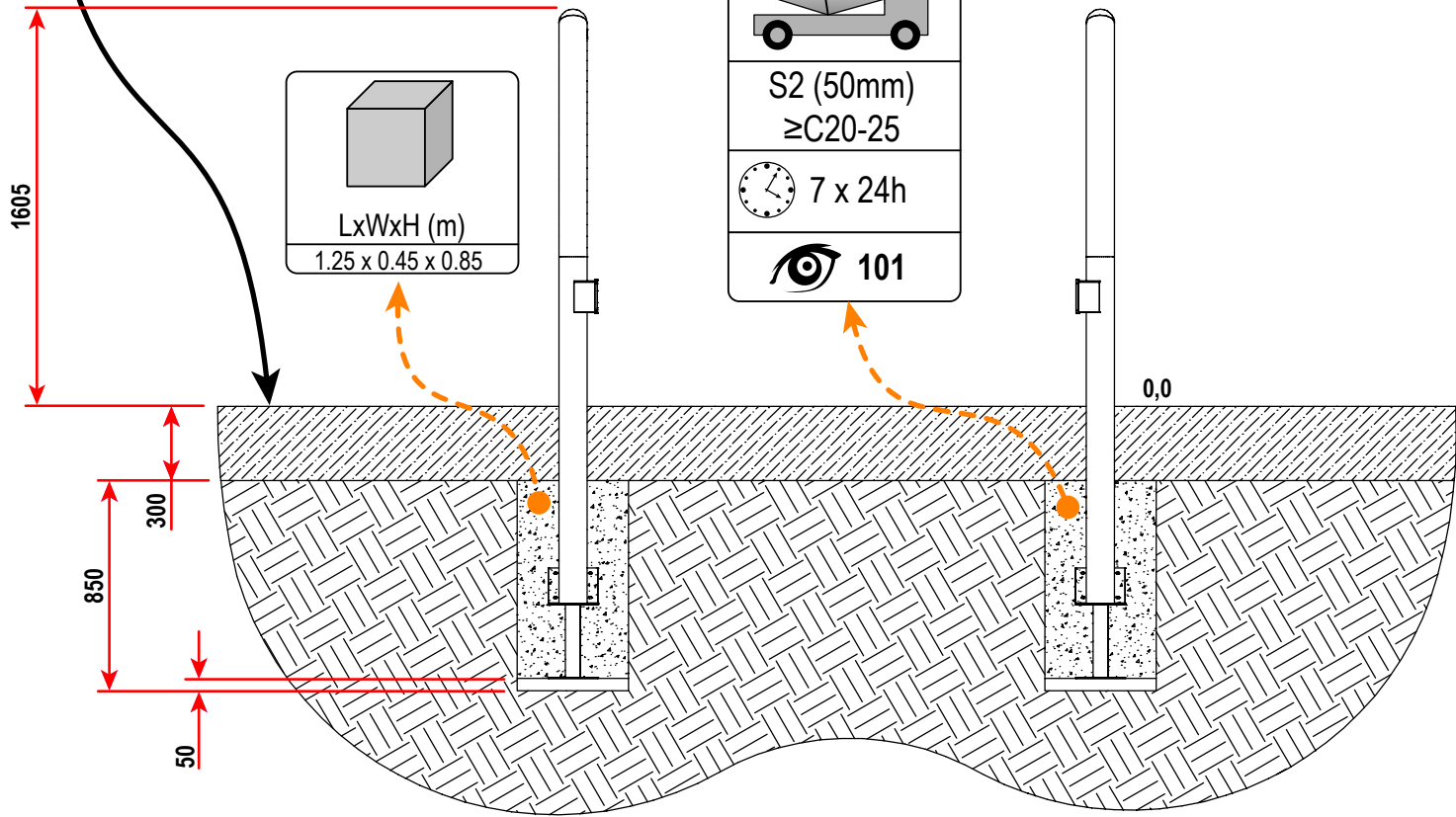
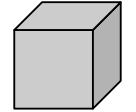

S2 (50mm)  
≥C20-25

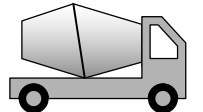



7 x 24h

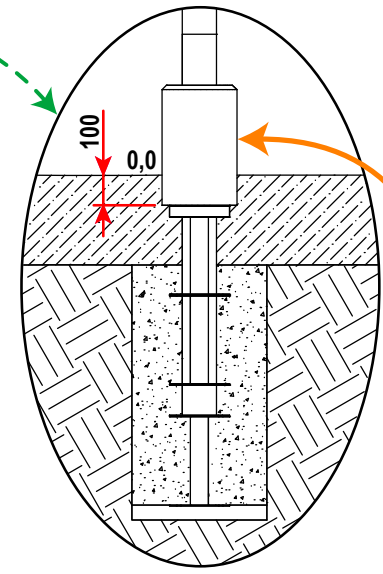

101





-  GB - Protect from concrete
- FR - Protéger contre le béton
- DE - Schutz vom Beton
- IT - Proteggere dal cemento
- ES - Proteger contra el hormigón
-  SE - Skyddas mot betong

**NG220S**

 **144**  
TYPE 3

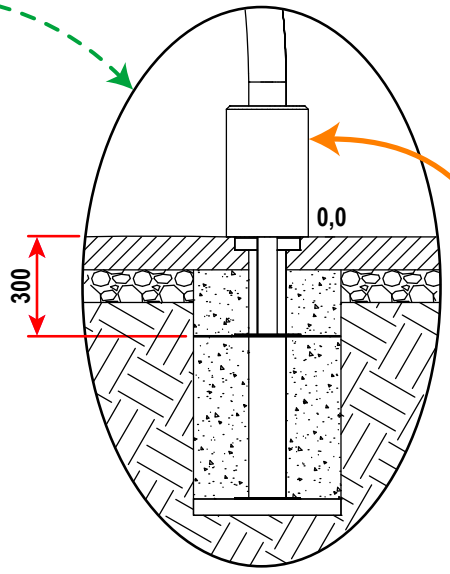
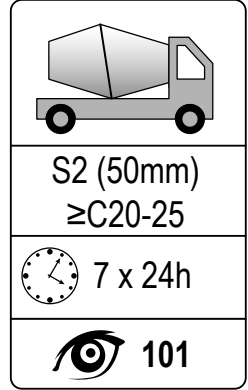
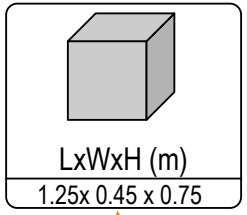
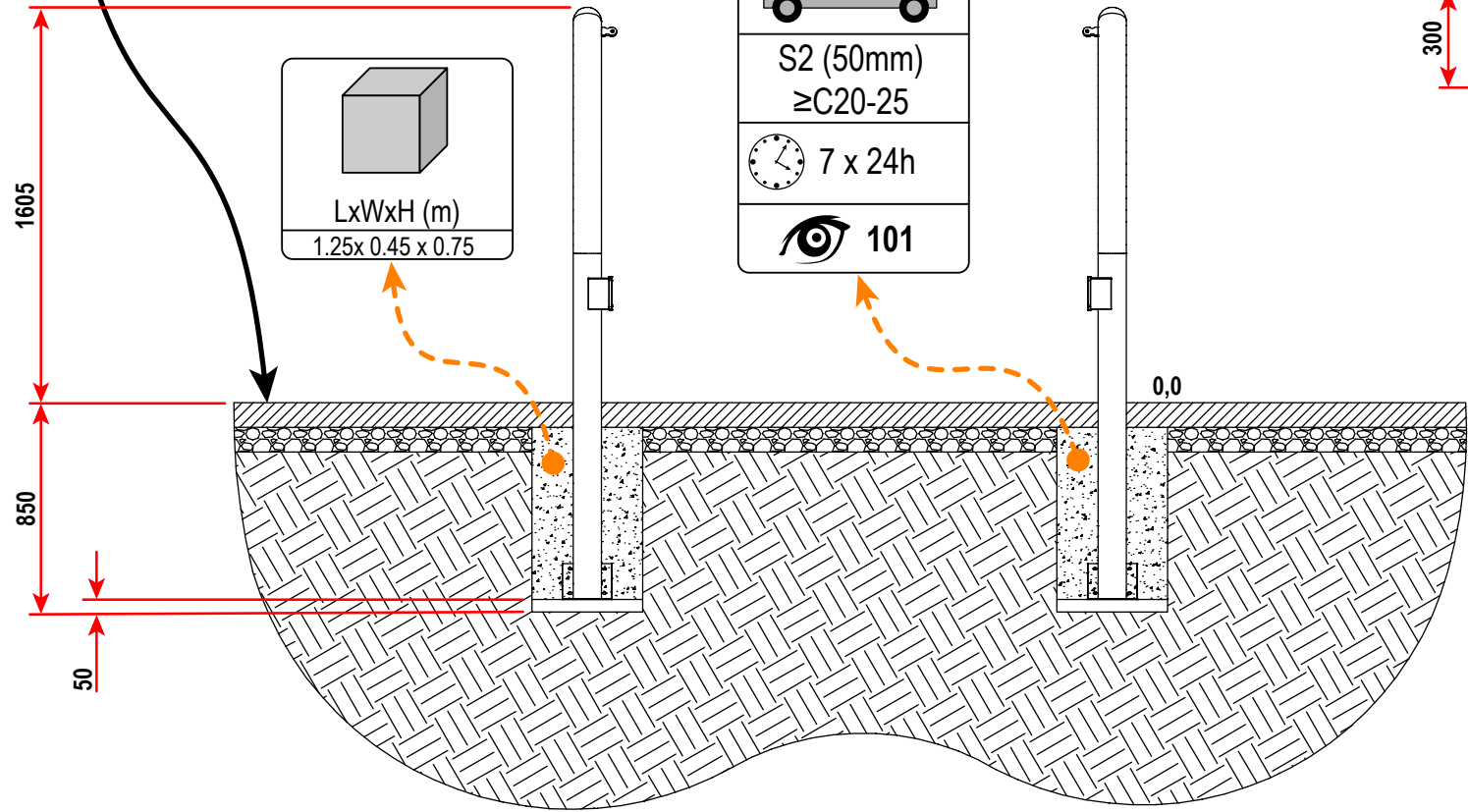
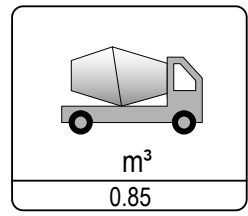
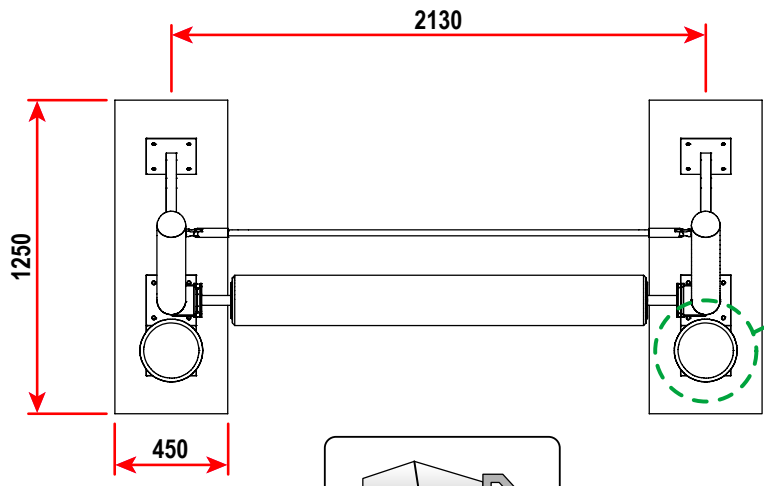
 **144**  
TYPE 5



-  GB - Protect from concrete
- FR - Protéger contre le béton
- DE - Schutz vom Beton
- IT - Proteggere dal cemento
- ES - Proteger contra el hormigón
-  SE - Skyddas mot betong

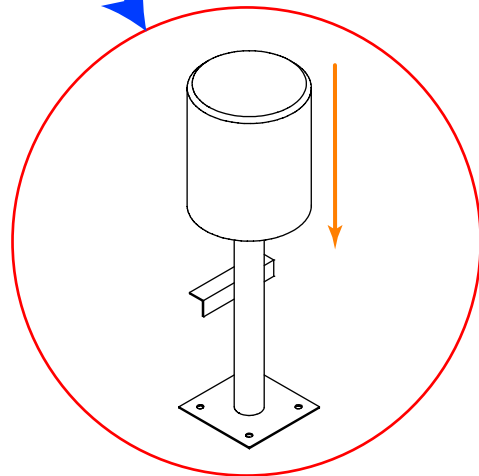
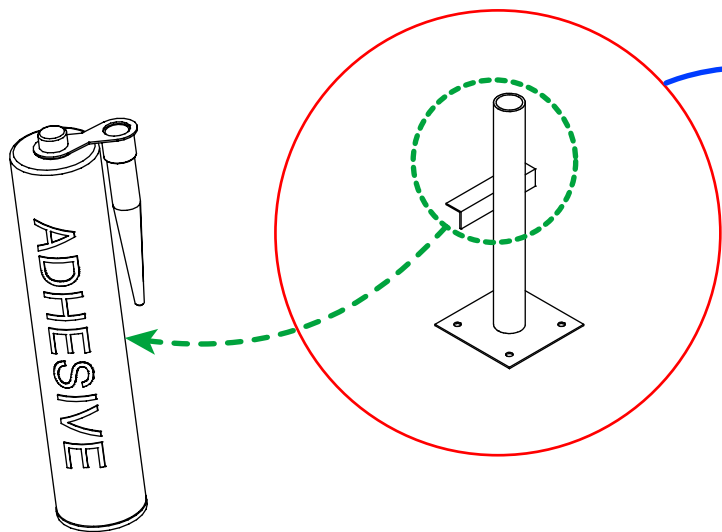
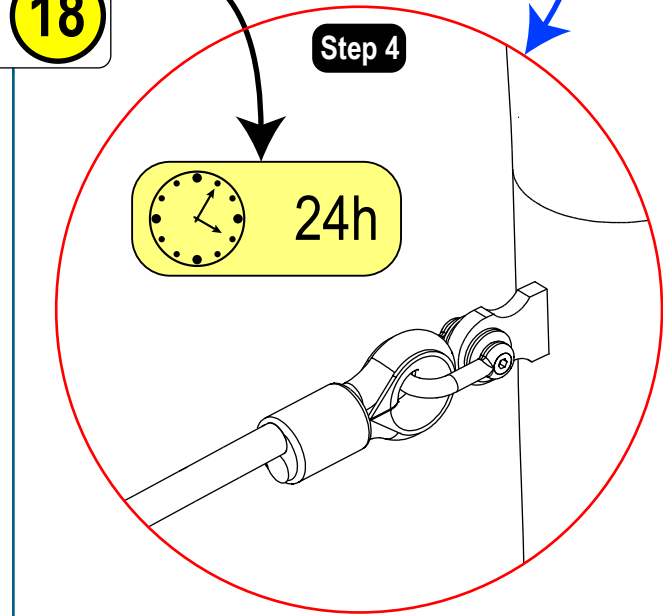
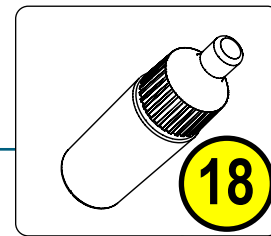
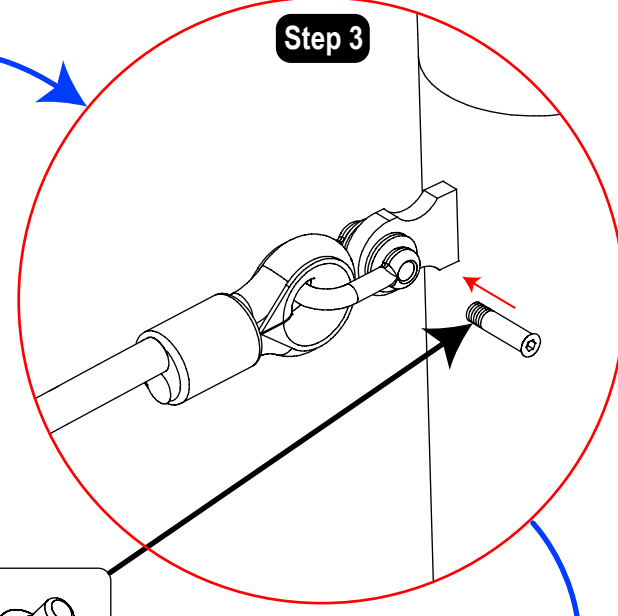
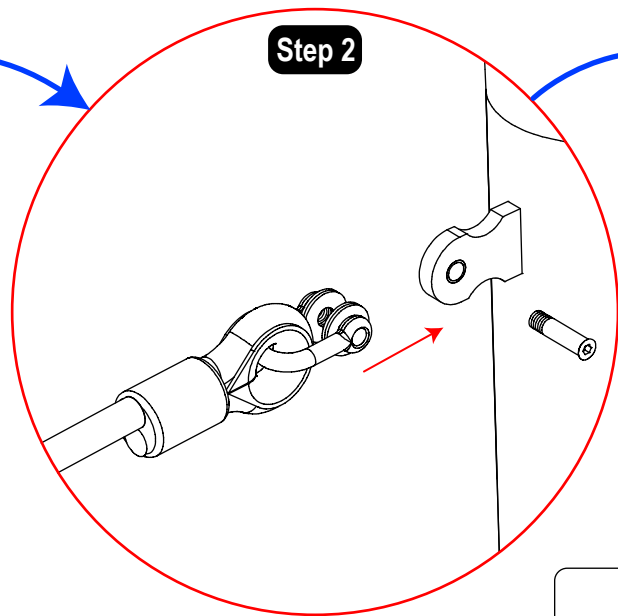
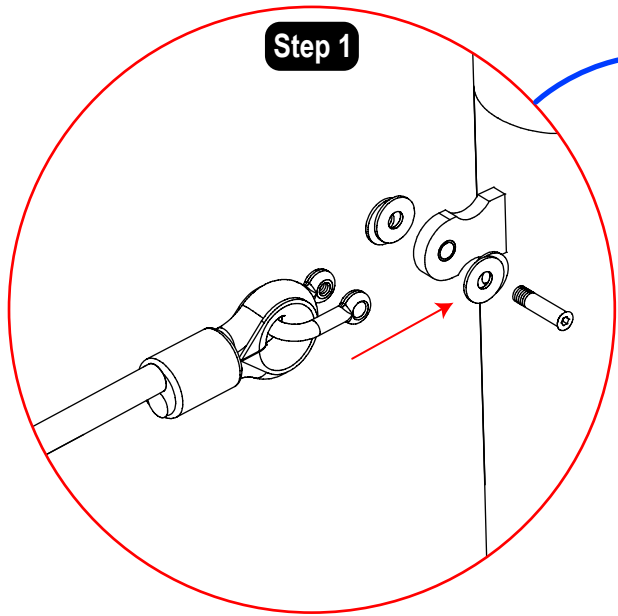

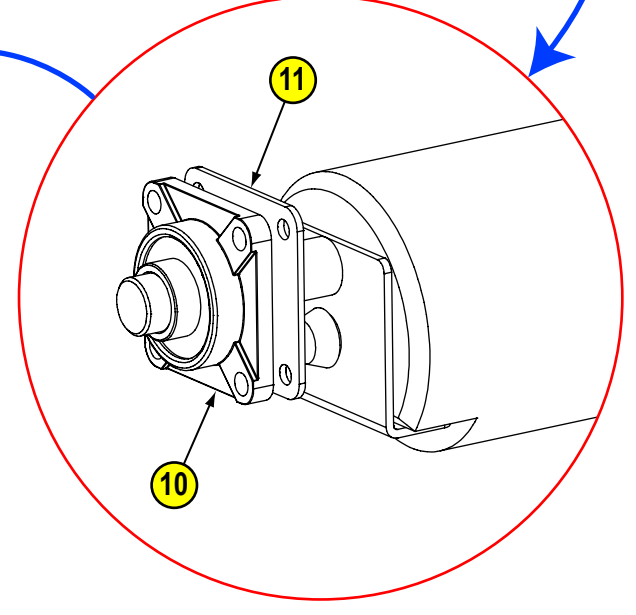
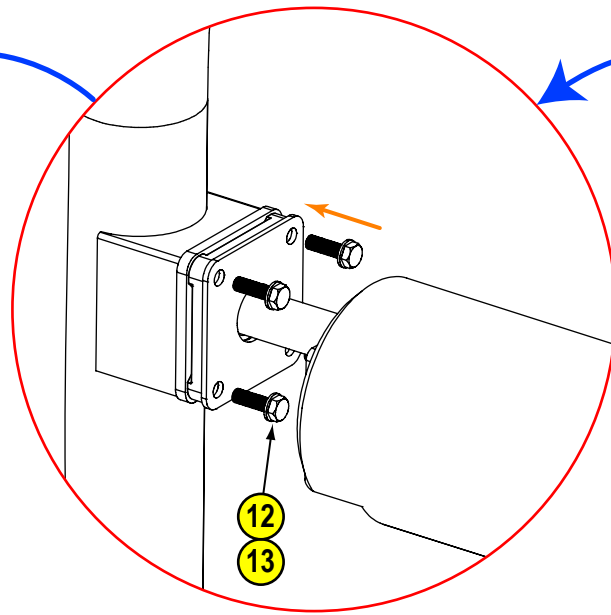
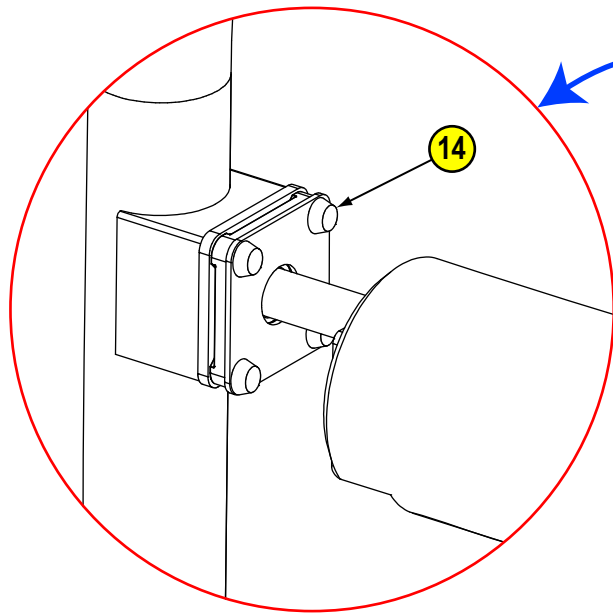
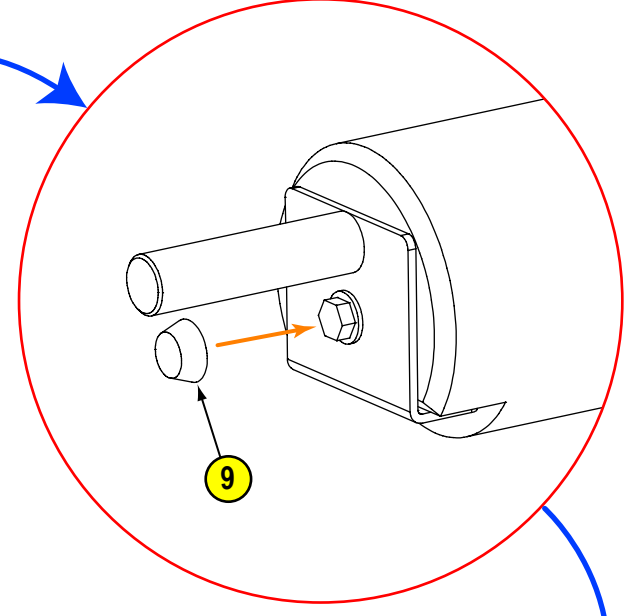
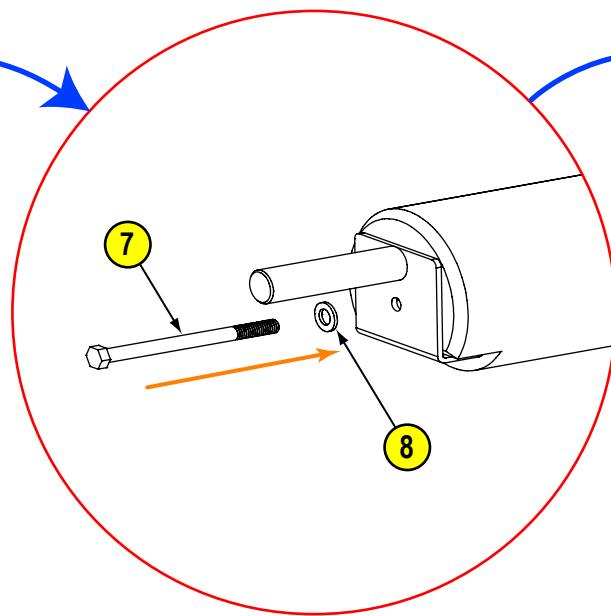
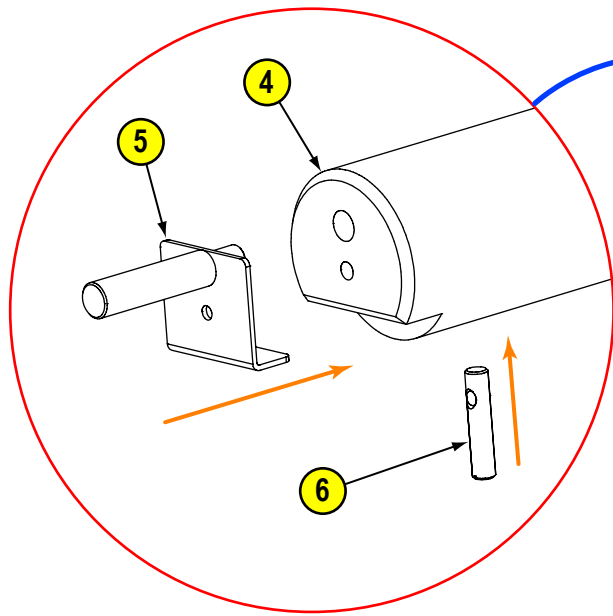

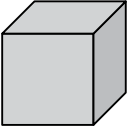

LxWxH (m)  
2.38 x 0.68 x 1.60

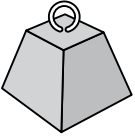

kg  
174



m<sup>3</sup>  
1.00

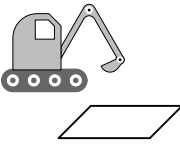

m<sup>2</sup>  
10 x 10



X 2 = T  
T = 8 hr

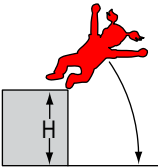

EN1176  
H=0.60m

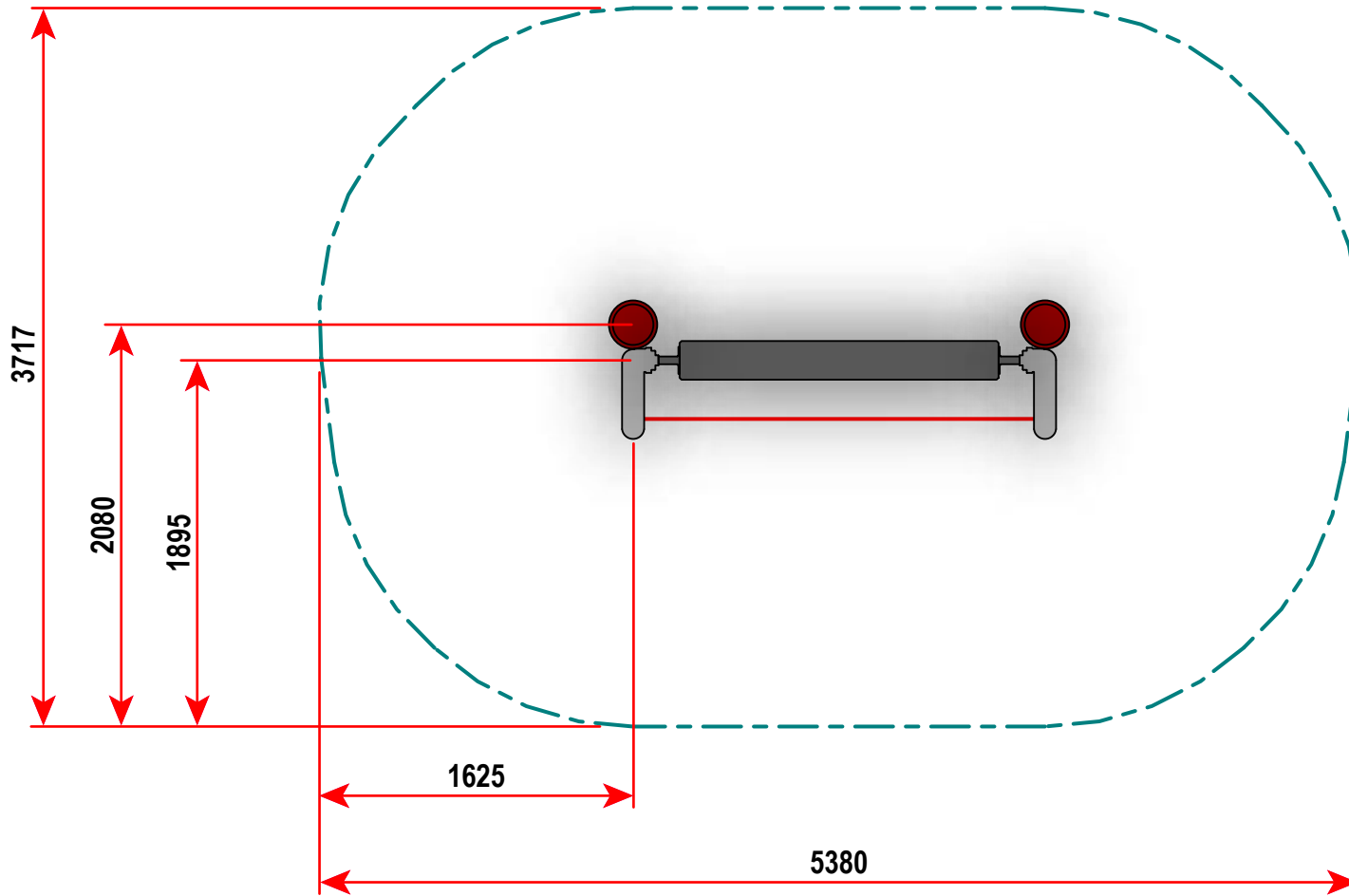

 **144**  
TYPE 5  
Grassmat

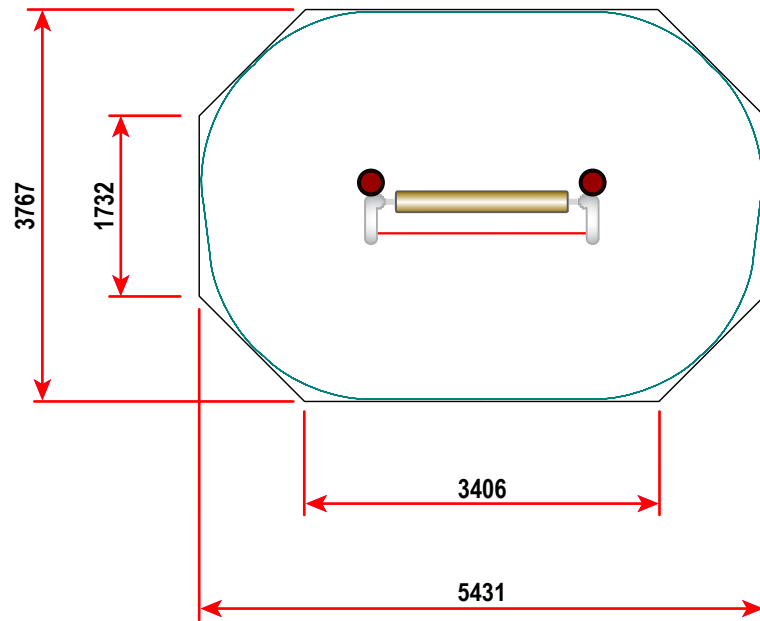

 **144**  
TYPE 3  
Synthetic

